

**TEAC DV-W28S-A93
CD-RW/DVD-MULTI RECORDER/DVD+RW**

HARDWARE SPECIFICATION

Rev. A

21 sheets in Total

TABLE OF CONTENTS

Title	Page
1. SCOPE	1
2. OUTLINE	1
3. CONSTRUCTION	2
3.1 External Construction	2
3.2 Installation	4
4. DISC SPECIFICATION	5
4.1 Applicable Disc Format	5
4.2 Rotational Speed	5
4.3 Data Capacity	6
4.4 Write Methods	6
4.5 Readable Disc	6
4.6 Recordable Disc (Recording Speed)	6
5. PERFORMANCE	7
5.1 Operating Performance	7
5.2 Acoustic Noise	7
6. ENVIRONMENTAL CONDITIONS	8
7. RELIABILITY	10
8. SAFETY AND EMC STANDARDS	10
9. FRONT INDICATOR	10
10. INTERFACE CONNECTOR	11
11. POWER INTERFACE	12
12. SERIAL ATA INTERFACE	13
12.1 Outline	13
12.2 Electrical Characteristics	13
12.2.1 Serial ATA options	13
12.3 COMMAND SET	13
12.3.1 ATA COMMAND	13
12.3.2 ATAPI COMMAND	14
13. POWER MANAGEMENT SPECIFICATION	16
13.1 Power Management Modes	16
13.1.1 Transition in power management mode	16
13.2 Active Mode	17
13.3 Idle Mode	17
13.4 Standby Mode	18
13.5 Sleep Mode	18
13.5.1 Tray ejection/insertion in the sleep mode	18
14. OTHERS	18
14.1 RoHS Compliance	18
14.2 Safety of Laser Products	19

1. SCOPE

This is hardware specification of the TEAC DV-W28S-A93 built-in type CD-RW/DVD-Multi recorder /DVD +RW (hereinafter referred to as drive). As for the software specification, refer to "DV-W28S-A Software Specification".

2. OUTLINE

The outline of this drive is given in Table 2-1.

(Table 2-1) Outline of the specification

Model name		DV-W28S-A93
TEAC P/N		1977273A-93
Applicable safety and EMC standards		UL, c-UL, TÜV, CE, C-tick, BSMI, KC
Interface transfer rate		1.5Gbps
Average access time		140msec (CD-ROM)/150msec (DVD-ROM), average by TEAC standards
Disc speed (24x CAV speed mode)		5,160min ⁻¹ (Approx)
Host interface		Serial ATA
Power source		+5VDC
Starting time		CD-ROM:14sec typ (excluding the multi-session CD) DVD-ROM:15sec typ (excluding dual layers and multi-border)
Readable discs	CD	CD-DA, CD-ROM, CD-R, CD-RW
	DVD	DVD-ROM, DVD-R, DVD-R DL, DVD-RW, DVD+R, DVD+R DL DVD+RW, DVD-RAM
Recordable discs		CD-R, CD-RW, DVD-R, DVD-R DL, DVD-RW, DVD-RAM (4.7GB), DVD+R, DVD+R DL, DVD+RW, (Refer to item 4.6)
Applicable format	CD	CD-DA, CD-ROM (Mode1, Mode2) CD-ROM XA Mode2 (Form1, Form2) Photo CD (Single/Multi-session), CD-i, Video-CD CD-Extra (CD-Plus), CD-Text
	DVD	DVD-ROM, DVD-Video, DVD-R (Single/Multi-border) DVD-R DL (Single/Multi-border) DVD-RW (Single/Multi-border), DVD+R (Single/Multi-session) DVD+R DL (Single/Multi-session) DVD+RW (Single/Multi-session), DVD-RAM (4.7GB)
Front bezel color		Black
Eject button color		Black
Access indicator		Green
Laser class		Class 1 laser product
Write methods	CD	Disc at once, Session at once, Track at once, Packet write
	DVD	Disc at once, Incremental, Over write, Sequential
RoHS directive		Complies with

3. CONSTRUCTION

3.1 External Construction

- (1) Dimensions
 - (a) Height : 12.7mm (excluding the front bezel)
 - (b) Width : 128mm (excluding the front bezel)
 - (c) Depth : 129.4mm (excluding the eject button)
- (2) Mass : 150g (without bezel)
- (3) Disc clamp system : Ball clamp
- (4) Loading : Manual loading using the tray
- (5) Ejection
 - (a) Manual eject using the eject button
 - (b) Automatically eject using the command
 - (c) Eject distance : 10mm or more
- (6) External view : Refer to Fig. 3.1-1.

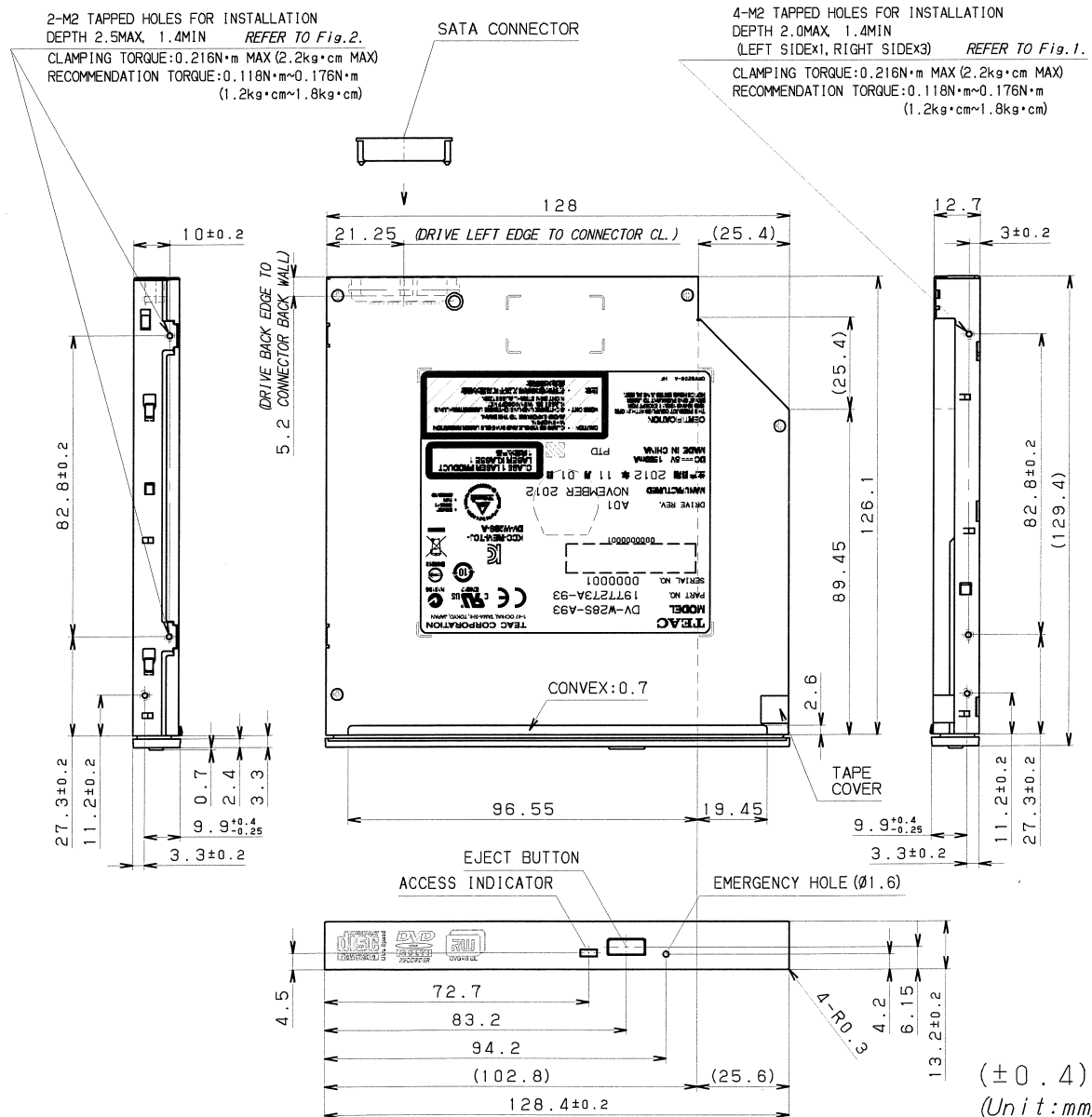
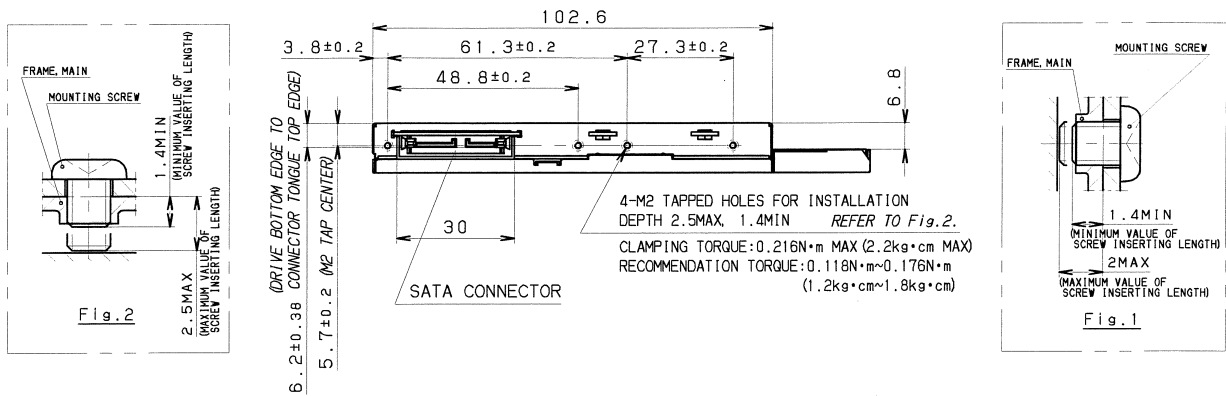

(Fig. 3.1-1) External view of the drive

3.2 Installation

- (1) Installation direction : Refer to Fig. 3.2-1.
- (2) Tilt : Refer to Fig. 3.2-1 below.
- (3) Installation method : The fixing holes in the side of the unit are used.
Separate discussions and arrangements are required when the installation holes are not used.

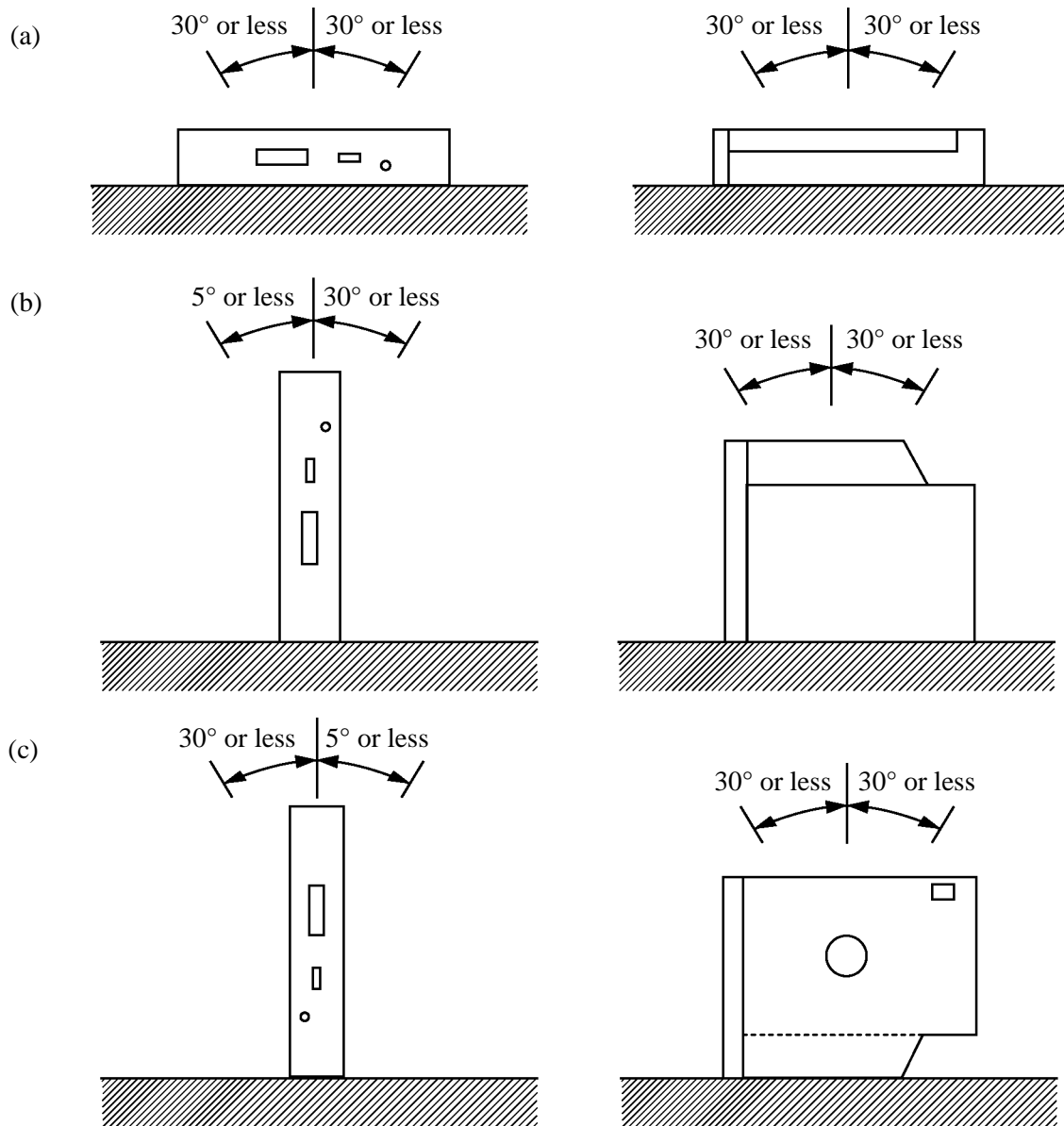

(Fig. 3.2-1) Tilt of the drive

4. DISC SPECIFICATION

4.1 Applicable Disc Format

Refer to Table 4.1-1.

(Table 4.1-1) Applicable disc format

CD	CD-DA CD-ROM (Mode1, Mode2) CD-ROM XA Mode2 (Form1, Form2) Photo CD (Single/Multi-session) CD-i Video-CD CD-Extra (CD-Plus) CD-Text
DVD	DVD-ROM DVD-Video DVD-R (Single/Multi-border), DVD-R DL (Single/Multi-border) DVD-RW (Single/Multi-border) DVD+R (Single/Multi-session), DVD+R DL (Single/Multi-session) DVD+RW (Single/Multi-session) DVD-RAM (4.7GB)

4.2 Rotational Speed

Refer to Table 4.2-1 for the rotational speed.

(Table 4.2-1) Rotational speed

Operation/Disc format	Read speed/Disc speed
Idle mode (DVD)	2x CLV 2,774 - 1,150rpm
Idle mode (DVD-RAM)	2x CLV 3,246 - 1,375rpm
Idle mode (CD)	4x CLV 1,833 - 790rpm
Read (DVD-ROM)	8x CAV 4,680rpm
Read (DVD-ROM DL)	8x CAV 4,680rpm
Read (DVD-Video)	4x CAV 2,340rpm
Read (DVD-RAM)	3 - 5x ZCLV 4,869 - 3,438rpm
Read (CD-ROM Model)	24x CAV 5,160rpm
Read (CD-ROM Video CD)	16x CAV 3,445rpm
Read (CD-DA)	24x CAV 5,160rpm
Play Audio	10x CAV 2,100rpm
Read (Mixed, CD-ROM Model and Mode2 Form2 or CD-DA)	(24x CAV 5,160rpm/10x CAV 2,100rpm)
Read (Mixed, DVD-ROM and DVD-Video)	(8x CAV 4,680rpm/4x CAV 2,340rpm)
Read (CD-RW)	24x CAV 5,160rpm
Read (DVD-R, DVD+R)	8x CAV 4,680rpm
Read (DVD-R DL)	8x CAV 4,680rpm
Read (DVD+R DL)	8x CAV 4,680rpm
Read (DVD-RW, DVD+RW)	8x CAV 4,680rpm

4.3 Data Capacity

- 650MB/700MB : CD-ROM Mode1
CD-ROM XA Mode2 Form1
- 738MB/795MB : CD-ROM XA Mode2 Form2
- 74min/79min : CD-DA
- 4.7GB/side : DVD-ROM, DVD-Video, DVD-R, DVD-RW, DVD-RAM, DVD+R,
DVD+RW
- 8.5GB/side : DVD-ROM, DVD-Video, DVD-R, DVD+R

4.4 Write Methods

CD	: Disc at once, Track at once, Session at once, and Packet write
DVD-R	: Disc at once, Incremental
DVD-RW	: Disc at once, Incremental, Over write
DVD+R	: Sequential (Multi-session)
DVD+RW	: Random write
DVD-RAM	: Random write

4.5 Readable Disc

CD-DA, CD-ROM, CD-R, CD-RW, DVD-ROM, DVD-R, DVD-R DL, DVD-RW, DVD+R, DVD+R DL, DVD+RW, DVD-RAM

4.6 Recordable Disc (Recording Speed)

With the recommended discs, the following speeds of recording are available:

(Table 4.6-1) Recording speed

CD-R	24x (CAV), 8 - 24x (ZCLV), 8 - 16x (ZCLV), 8x (CLV)
CD-RW	8 - 24x (ZCLV), 8 - 20x (ZCLV), 8 - 16x (ZCLV), 8 - 10x (ZCLV), 8x (CLV), 4x (CLV)
DVD-R	8x (CAV), 2 - 8x (ZCLV), 2 - 6x (ZCLV), 2 - 4x (ZCLV), 2x (CLV)
DVD-R DL	2 - 6x (ZCLV), 2 - 4x (ZCLV), 2x (CLV)
DVD-RW	2 - 6x (ZCLV), 2 - 4x (ZCLV), 2x (CLV), 1x (CLV)
DVD-RAM	3 - 5x (ZCLV), 3x (ZCLV), 2x (ZCLV)
DVD+R	8x (CAV), 2.4 - 8x (ZCLV), 2.4 - 6x (ZCLV), 2.4 - 4x (ZCLV), 2.4x (CLV)
DVD+R DL	2.4 - 6x (ZCLV), 2.4 - 4x (ZCLV), 2.4x (CLV)
DVD+RW	2.4 - 4x (ZCLV), 2.4x (CLV)
DVD+RW (HS)	3.3 - 8x (ZCLV), 3.3 - 6x (ZCLV), 3.3x (CLV)

5. PERFORMANCE

5.1 Operating Performance

- (1) Average random access time : 140msec average (CD-ROM, 24x), 150msec average (DVD-ROM, 8x)
- (2) Disc speed : Refer to Table 4.2-1.
- (3) Data transfer rate
 - (a) Read sustained : 1,545 to 3,600kB/sec (CD-ROM Model)
4,469 to 10,816kB/sec (DVD-ROM)
 - (b) Programmed I/O : 16.7MB/sec max (Mode 0 to 4)
 - (c) Multi-word DMA : 16.7MB/sec max (Mode 0 to 2)
 - (d) Ultra DMA : 100MB/sec max (Mode 0 to 5)
- (4) Starting time
 - (a) When power is switched on/when disc is loaded
 - CD-ROM : 12sec typ (excluding the multi-session CD)
 - DVD-ROM : 13sec typ (excluding dual layers and multi-border)
 - (b) Return time from the standby mode
 - CD-ROM : 4sec or less
 - DVD-ROM : 4sec or less
- (5) Data buffer capacity : 0.5MB

5.2 Acoustic Noise

- (1) Operating : 45dBA or less (during seek/read/write/Active/Idle, distance 0.5m)
- (2) Ejecting : 65dBA or less (distance 0.5m)
- (3) Others : 35dBA or less (distance 0.5m)

6. ENVIRONMENTAL CONDITIONS

The environmental conditions as specified here do not include the environmental conditions of the disc. The environmental conditions of the disc should follow the specifications of the applicable disc.

- (1) Ambient temperature
 - (a) During operation : 5 to 45°C (Surface temperature on the top cover and the main frame; 5 to 55°C)
The recording speed may be limited or reduced even in the above temperature due to the temperature sensitive function in the pickup.
 - (b) During non-operation : -20 to 60°C
 - (c) During transportation (packaged) : -40 to 65°C
- (2) Temperature gradient
 - (a) During operation : 11°C/hour or less (non-condensing)
 - (b) During non-operation/transportation : 20°C/hour or less (non-condensing)
- (3) Relative humidity
 - (a) During operation : 8 to 80% (non-condensing)
provided that the maximum wet-bulb temperature is 29.4°C or less.
 - (b) During non-operation/transportation : 5 to 95% (non-condensing)
provided that the maximum wet-bulb temperature is 29.4°C or less.
 - (c) During transportation (packaged) : 5 to 95% (non-condensing)
provided that the maximum wet-bulb temperature is 29.4°C or less.
- (4) Vibrations
 - (a) During operation : When installed horizontally: 2.9m/s² (0.3G) or less
When installed vertically : 1.96m/s² (0.2G) or less
provided that the sweep frequency is 10 to 500Hz and sweep rate, 1oct/min.
excepting recording mode.
 - (b) Transportation (packaged) : 19.6m/s² (2G) or less provided that the sweep frequency is 10 to 500Hz and sweep rate, 1oct/min.
- (5) Shock
 - (a) During operation (free from malfunction)
 - : When installed horizontally: 68.6m/s² (7G) or less (half-sine shock pulse; 11msec, intervals; 10sec)
 - When installed vertically : 49m/s² (5G) or less (half-sine shock pulse; 11msec, intervals; 10sec)
 excepting recording mode and CD-DA play mode.
 - (b) During operation (while the CD-DA is playing) : 19.6m/s² (2G) or less (half-sine shock pulse; 11msec, intervals; 10sec)
 - (c) During non-operation/transportation
 - : 588m/s² (60G) or less (half-sine shock pulse; 11msec)
 - 1,960m/s² (200G) or less (half-sine shock pulse; 2msec)
 However, tray ejection is allowed.

- (6) Dust : Office environment
- (7) Cooling : Natural air cooling

7. RELIABILITY

- (1) Mean time between failures (MTBF)
 - : 60,000 POH or more (the frequency of use should be 10% at normal temperature and humidity)
- (2) Mean time to repair (MTTR) : 30 minutes
- (3) Loading/ejecting life : 10,000 times or more
- (4) Power ON/OFF life : 60,000 times or more
- (5) Laser diode life
 - (a) CD : MTTF 100,000 hours (Duty 40% pulse 380mW, 85°C)
 - (b) DVD : MTTF 31,700 hours (Duty 35% pulse 280mW, 85°C)
- (6) Seeking life : 2×10^6 times or more (random access, 25°C, duty; 20% or less)
- (7) Error rate
 - (a) Read error rate
 - DVD : Once per 10^{12} bits or less
 - CD : Mode1 and Mode2 (Form1) : Once per 10^{12} bits or less
Mode2 (Form2) and CD-DA : Once per 10^9 bits or less
 - (b) Seek error rate : Once per 10^6 seeks or less
- (8) Self-diagnosis
 - (a) When power is switched ON: Various controllers, ROM, RAM, buffer, ECC circuit, etc.
 - (b) When disc is inserted : Servo circuit, signal processors, etc.

8. SAFETY AND EMC STANDARDS

The drive complies with the following standards.

- (1) Safety standards
 - UL, c-UL, TÜV, CE
- (2) EMC standards
 - CE, C-tick, BSMI, KC

9. FRONT INDICATOR

- (1) Location : Refer to Fig. 3.1-1.
- (2) Color : Green
- (3) Lighting conditions
 - (a) Continuous on
 - During seek.
 - Transfer of the read data to the host is under way.
 - (b) Flashing with a period of 3 second (Duty 50%)
 - During write.
 - While audio is being played.
 - (c) Flashing with a period of 1 second (Duty 50%)
 - From POR or tray loading to the end of TOC read (when the disc is present).
 - From POR or tray loading to the end of detecting the disc (when the disc is not present). If an error which is considered to arise from the disc occurs, flashing continues until the disc is ejected. If an error which seems to rest with the drive's hardware, flashing continues until the power is switched OFF.
 - (d) Flashing with a period of 0.5 second (Duty 50%)
 - During ejection.

10. INTERFACE CONNECTOR

- (1) Connector on the drive : MOLEX 47300-1040 or equivalent
- (2) Applicable connector on the host : MOLEX 47300-2010 or equivalent
- (3) Pin assignment : Refer to Table 10-1, Fig. 10-1.

(Table 10-1) Interface connector pin assignment

NAME	TYPE	DESCRIPTION
S1	GND	
S2	A+	Differential Signal Pair A
S3	A-	
S4	GND	
S5	B-	Differential Signal Pair B
S6	B+	
S7	GND	
P1	DP	Device Present (1KΩ Pull Down)
P2	+5V	
P3		
P4	MD/DA	Manufacturing Diagnostic / Device Attention
P5	GND	
P6		

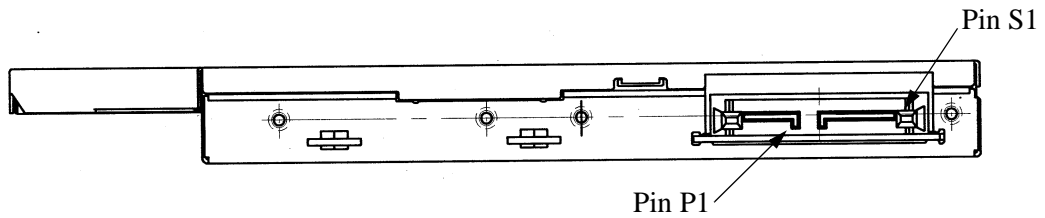

(Fig. 10-1) Interface connector assignment

11. POWER INTERFACE

The following specifications apply to the interface connector terminals of the drive. The power should be supplied from a power supply unit with reinforced insulation or double insulation.

- (1) Allowable supply voltage range : +5VDC \pm 5% (4.75 to 5.25V)
- (2) Allowable ripple voltage : 100mVp-p or less, 50 to 20MHz (including the spike noise)
- (3) Current consumption : Refer to Table 11-1.

(Table 11-1) Current consumption

Mode	Average current max (A)	Peak current max (A)
Standby/Sleep	49/49 (mA)	–
Write 24x (CD-R)	0.8	–
Active	0.7	–
Random access (Duty 100%)	1.0	1.3
During starting/seek	–	1.5
During eject	–	0.7

Remarks:

1. The supply voltage should be 5V+5%.
2. For each of the sleep, standby, and active modes, refer to "**13. POWER MANAGEMENT SPECIFICATION**".
3. Does not include pulse-like current below 1msec.

12. SERIAL ATA INTERFACE

12.1 Outline

- (1) Applicable standard
- | | |
|---------------------------------------|---------------------------------------|
| Serial ATA International Organization | : Serial ATA Revision 3.0 |
| ANSI standard | : T13/1532D (ATA-7) |
| SFFC | : SFF-8020i Rev. 2.6 and INF-8090i v7 |

12.2 Electrical Characteristics

Refer to Serial ATA Revision 3.0.

12.2.1 Serial ATA options

- | | |
|-----------------------------------|-------|
| (1) Asynchronous Signal Recovery | : yes |
| (2) Software Setting Preservation | : yes |
| (3) Interface Power Management | |
| device initiated | : no |
| host initiated | : no |
| (4) Spread Spectrum Clocking | : no |

12.3 COMMAND SET

12.3.1 ATA COMMAND

Refer to Table 12.3.1-1.

(Table 12.3.1-1) ATA COMMAND

CODE	COMMAND
08	ATAPI SOFT RESET
E5	CHECK POWER MODE
90	EXECUTE DRIVE DIAGNOSTIC
E3	IDLE
E1	IDLE IMMEDIATE
00	NOP
A0	ATAPI PKT.
A1	ATAPI IDENTIFY DEVICE
EF	SET FEATURE
E6	SLEEP
E2	STANDBY
E0	STANDBY IMMEDIATE

12.3.2 ATAPI COMMAND

Refer to Table 12.3.2-1.

(Table 12.3.2-1) List of the ATAPI commands (Sheet 1 of 2)

CODE	COMMAND
A1	BLANK
5B	CLOSE TRACK/RZONE/SESSION/BORDER
04	FORMAT UNIT
4A	GET EVENT STATUS NOTIFICATION
12	INQUIRY
BD	MECHANISM STATUS
55	MODE SELECT
5A	MODE SENSE
4B	PAUSE/RESUME
45	PLAY AUDIO (10)
A5	PLAY AUDIO (12)
47	PLAY AUDIO MSF
49	PLAY TRACK RELATIVE (10)
A9	PLAY TRACK RELATIVE (12)
1E	PREVENT/ALLOW MEDIUM REMOVAL
28	READ (10)
A8	READ (12)
5C	READ BUFFER CAPACITY
25	READ CD/DVD CAPACITY
BE	READ CD
B9	READ CD MSF
51	READ DISC INFORMATION
44	READ HEADER
42	READ SUB-CHANNEL
43	READ TOC/PMA/ATIP
52	READ TRACK/RZONE INFORMATION
03	REQUEST SENSE
53	RESERVE TRACK/RZONE
01	REZERO UNIT
BA	SCAN
2B	SEEK
5D	SEND CUE SHEET
54	SEND OPC INFORMATION
BB	SET CD-ROM SPEED
1B	START/STOP UNIT
4E	STOP PLAY/SCAN
35	SYNCHRONIZE CACHE

(Table 12.3.2-1) List of the ATAPI commands (Sheet 2 of 2)

CODE	COMMAND
00	TEST UNIT READY
2A	WRITE (10)
AA	WRITE (12)
AD	READ DVD STRUCTURE
23	READ FORMAT CAPACITIES
A4	REPORT KEY
A3	SEND KEY
A7	SET READ AHEAD
46	GET CONFIGURATION
AC	GET PERFORMANCE
BF	SEND DVD STRUCTURE
B6	SET STREAMING

13. POWER MANAGEMENT SPECIFICATION

This drive has a power management function to reduce power consumption.

13.1 Power Management Modes

The drive has the following four power management modes. The transition between these modes is performed by the timer within the drive or a command issued by the host.

- Active mode
- Idle mode
- Standby mode
- Sleep mode

13.1.1 Transition in power management mode

The transition in the power management mode is shown in Fig. 13.1.1-1.

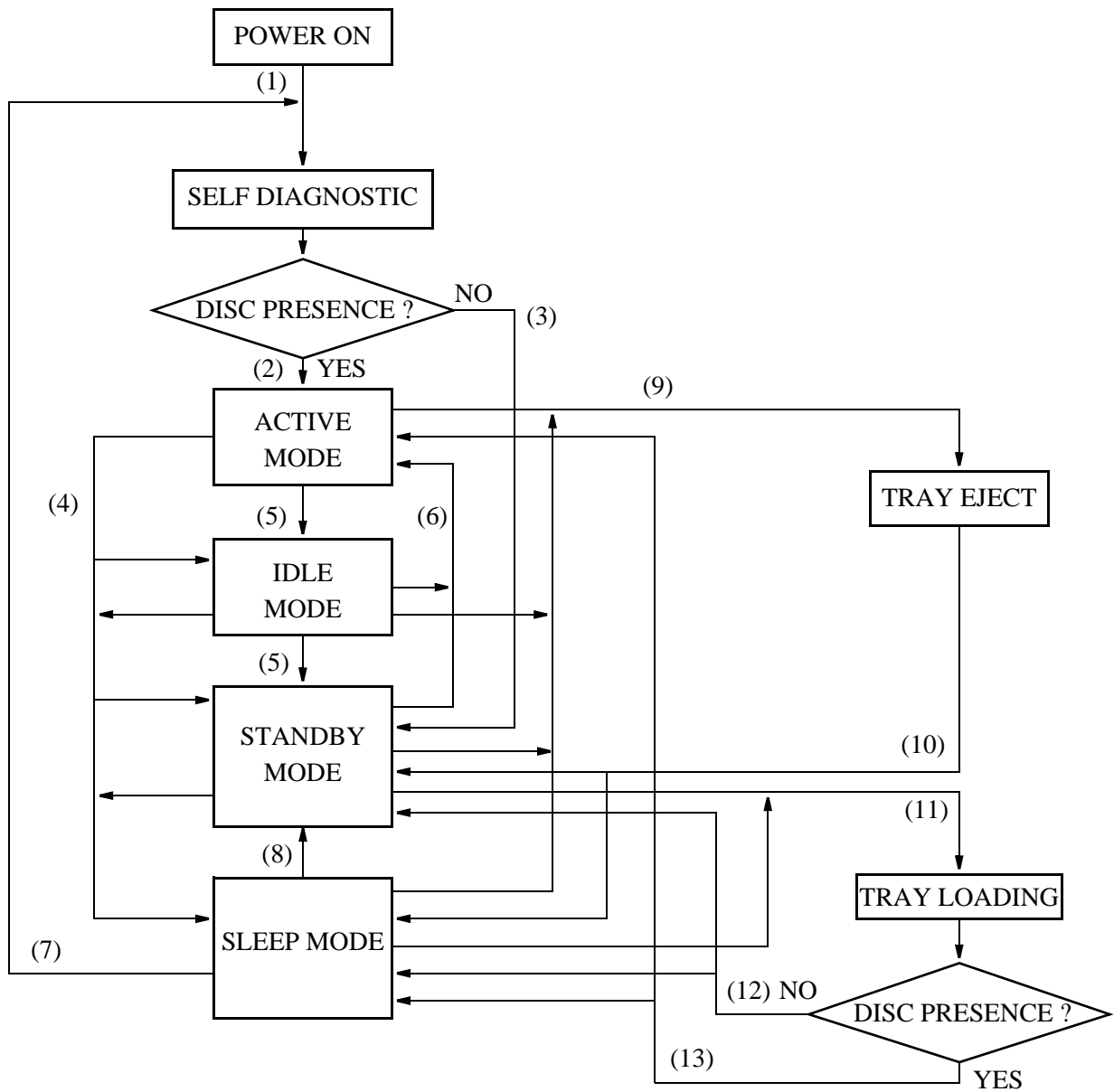

(Fig. 13.1.1-1) Transition in power management mode

- (1) When the RESET signal is released, the disc detection is performed after self-diagnostics are completed.
- (2) If the disc is loaded, the mode will switch to the active mode and starting operation will begin.
- (3) If the disc is not loaded, the mode will switch to the standby mode.
- (4) Using the power management command (IDLE, IDLE IMMEDIATE, STANDBY, STANDBY IMMEDIATE, SLEEP), the transition from the active mode to the idle, standby or sleep mode, from the idle mode to the standby or sleep mode, or from the standby mode to the idle or sleep mode is possible.
- (5) The transition from the active mode to the idle mode or from the idle mode to the standby mode is also performed by the timer in the drive. The timer will be initialized to the specified value when disc detection operation is under way or when a command which requires disc access is executed. The timer will not be initialized when a command which does not require disc access is executed in the active mode.
- (6) The resumption from the idle or standby mode to the active mode is initiated when a command which requires disc access is executed.
- (7) The resumption after the sleep mode is possible only after the RESET signal, the SRST (bit 2 of the DEVICE Control Register) or the ATAPI SOFT RESET command is detected. If resumption after the sleep mode is initiated using the RESET signal, an operation similar to when the power is switched ON occurs.
- (8) If resumption after the sleep mode is initiated using the SRST or the ATAPI SOFT RESET command, the drive enters the standby mode.
- (9) Tray ejection in each of the active, idle, standby and sleep modes is possible.
- (10) If the tray is ejected in the active, idle or standby mode, the drive enters the standby mode when the tray is out or the sleep mode when the tray is ejected in the sleep mode.
- (11) If the tray is inserted when the tray is out, the disc detection operation is performed.
- (12) If no disc is loaded, the drive will resume a mode when the tray is out.
- (13) If the disc is loaded, the drive will resume the active mode. However, the drive resumes the sleep mode following the TOC read only when the tray is ejected in the sleep mode.

13.2 Active Mode

A state in which the drive is capable of responding in the shortest possible time to an access using a command, and all the electrical circuitry of the drive, the pickup, spindle motor and sled motor are operating. In the following cases, the drive will enter the active mode:

- (1) While it is being booted after the power is switched ON and self diagnosis is under way.
- (2) While the booting operation or Reading of the TOC is under way when the tray is inserted and the disc is loaded.
- (3) While the booting operation or Reading of the TOC is in progress with the power ON and the disc loaded.
- (4) While an command that requires disc access is being executed.
- (5) Until the drive switches over to other power management mode using the timer in the drive or the command after either (2), (3) or (4) above is performed.

13.3 Idle Mode

The idle mode has the same operational functions as the active mode. However, the current consumption is reduced by lowering the rotational speed of the spindle motor in the idle mode.

The transition to the idle mode comes in the following two ways:

- (1) When using the timer in the drive:

After executing (2), (3) and (4) in 13.2, if the specified time elapses by the timer in the drive, the mode will switch from the active mode to the idle mode.

The specified time of the timer is set to 8 seconds.
- (2) When using the power management command (IDLE, IDLE IMMEDIATE):

The transition from the active or standby mode is possible using the power management command (IDLE, IDLE IMMEDIATE).

For details, refer to the Software Specification.

13.4 Standby Mode

Except for the functions required for the reception of a command, all other functions are in the power save condition. And although the command can be received, a time is required to restore the functions that are in the power save condition for the command that requires disc access. The transition to the standby mode comes in the following three ways:

- (1) When using the timer in the drive:

After executing (2), (3) and (4) in 13.2, if the specified time elapses by the timer in the drive, the mode will switch from the active to the standby mode via the idle mode.

Although the specified time of the timer can be preset using the STANDBY command or MODE SELECT command, it is set to 32 seconds by default. The transition time to the idle mode is included in the preset value of the timer.

For details, refer to the Software Specification. The timer will be initialized to the specified value after executing (2), (3) and (4) in 13.2. The timer will not be initialized when a command which does not require disc access is executed in the active mode.

- (2) When using the power management command (STANDBY, STANDBY IMMEDIATE) or START/STOP UNIT command:

The transition from the active or idle mode is possible using the power management command (STANDBY, STANDBY IMMEDIATE) or START/STOP UNIT command.

For details, refer to the Software Specification.

- (3) When the power is switched ON or a disc is not detected by the disc detection operation while the tray is being retracted, the drive will enter the standby mode.

13.5 Sleep Mode

The drive enters a state in which all functions are stopped and no command can be received.

The transition to the sleep mode is possible using the SLEEP command.

For details, refer to the Software Specification. The resumption from the sleep mode is possible using the RESET signal, the SRST (bit 2 of the Device Control Register) or the ATAPI SOFT RESET command.

13.5.1 Tray ejection/insertion in the sleep mode

If the eject button is pressed in sleep mode, the tray will be ejected before sleep mode is entered. If the tray is inserted while in this state, disc detection is performed; If the disc is loaded on the tray, the start-up operation is performed before sleep mode is entered. If the disc is not loaded on the tray, sleep mode is entered.

14. OTHERS

14.1 RoHS Compliance

The drive complies with European directive "2002/95/EC".

EU Importer name and address

TEAC EUROPE GmbH

Bahnstrasse 12, 65205 Wiesbaden - Erbenheim, Germany

14.2 Safety of Laser Products

When selling this unit or a system with this unit to an end user, print the following text in the instruction manual or enclose the separate sheet on which the following text is printed with the instruction manual.

This product complies with Standard IEC60825-1:2007.

This product has been designed and manufactured according to FDA regulations "title 21, CFR, chapter 1, subchapter J, based on the radiation Control for Health and Safety Act of 1968", and is classified as a class 1 laser product. There is no hazardous invisible laser radiation during operation because invisible laser radiation emitted inside of this product is completely confined in the protective housings.

The label required in this regulation is shown bellow.

CAUTION
Use of controls or adjustments or performance of procedures other than those specified herein may result in hazardous radiation exposure.

Optical pickup	
Type	: SW 671L
Manufacturer	: Hitachi Media Electronics Co., Ltd.
Laser output	: Less than 95mW (DVD) and 130.7mW (CD) on the objective lens
Wavelength	: 783nm (CD) typ 661nm (DVD) typ
Standard	: IEC60825-1 : 2007

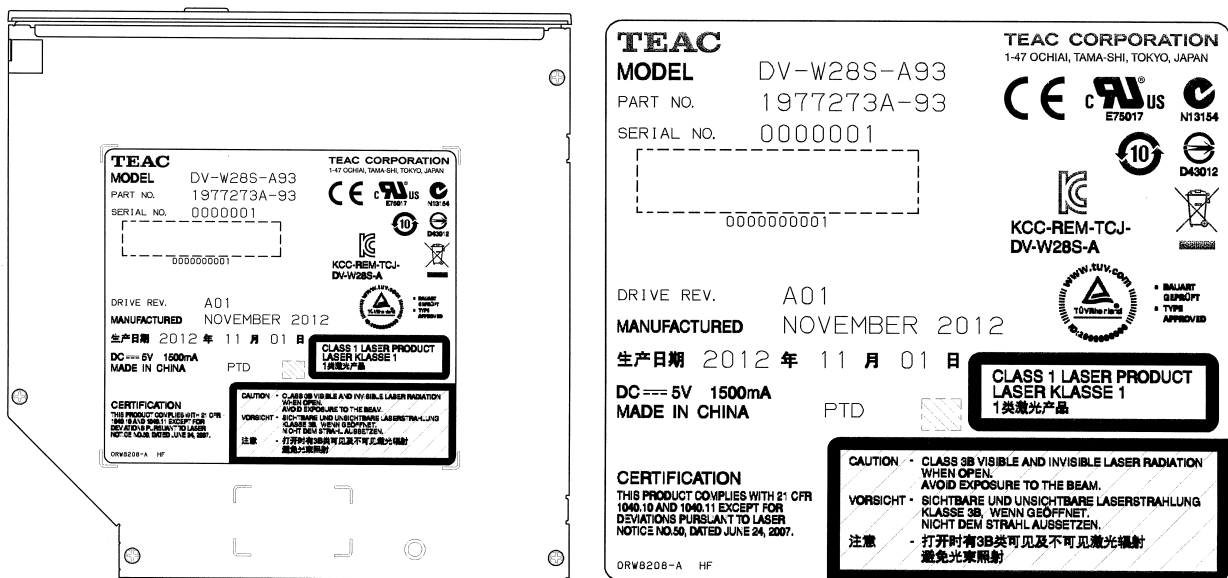

(Fig. 14.2-1)